



**BMS Interface for
Toshiba
Air-Conditioning**

Installation and User Guide

BACnet™ is a registered trademark of ASHRAE (American Society of Heating, Refrigerating and Air-Conditioning Engineers, Inc.)

Contents

1. Supplied Parts	2
2. Important Information	3
3. Product Overview	4
3.1 Product Variants	4
4. Connection Details	5
4.1 Power Supply	5
4.2 HVAC Communications Network (TCC-LINK)	5
4.3 Serial Communications Ports	6
4.4 Digital Input / Output	7
4.5 USB	7
4.6 Ethernet	7
5. Air-Conditioning Address Configuration	8
6. User Interface (Display Version)	10
6.1 Main Menu	11
6.2 System Overview	12
6.3 Unit Status Screen	13
7. Modbus Interface	14
7.1 Port Configurations	14
7.2 HVAC Status and Control Registers	15
7.3 Additional Register Usage	16
7.4 Parameter Settings	17
7.5 Modbus Table Overview	18
8. Trend Interface (TT-64x only)	20
8.1 Trend Process Description	21
8.2 Trend IQx Outstation Configuration	22
8.3 Parameter Settings	23
9. BACnet Interface (TB-64x only)	24
9.1 Object Types	25
9.2 Service List	25
9.3 Object List	26
9.4 Object Names	28
9.5 System Objects	29
Appendix A : Physical Dimensions	30
Appendix B : Reset Button and Factory Defaults	31
Appendix C : Trend Outstation Memory Usage (TT-64x only)	33
Appendix D : Toshiba Error Code Cross-Reference	35
Appendix E : Document Revision History	37

1. Supplied Parts



Black Pear with display

or



Black Pear without display



USB cable



Cat-5 'Straight-Through'
Ethernet cable



DIN-rail clips

2. Important Information

- **All electrical work should be carried out by a competent person and wiring must be in accordance with the national electrical installation regulations.**
- **Ensure that installation work is done correctly using the information contained in this manual.**
- **Make all connections securely so that any outside forces acting on the cables are not applied to the terminals.**
- **Never modify or repair the Black Pear by yourself.**
Any attempt to do so will void the warranty.
- **To dispose of this product, consult your dealer.**

**This unit will require setting up, using the free configuration software available on our website.
Please go to www.microtrol.co.uk and click on the 'Support' link.**

3. Product Overview

The Black Pear allows a building management system (BMS) to monitor and control air-conditioning units on a Toshiba air-conditioning system without the need for a central controller.

The unit incorporates a port which allows direct connection to the Toshiba TCC-LINK network and allows up to 64 groups to be monitored and controlled.

There are 2 hardware variants, one with an LCD display and one with LED indicators. The display version also includes a simple keypad. providing convenient local control.

There are 3 models, each available with or without a display, providing different protocol solutions:

TM-64, TM-64D Modbus RTU via RS232 / RS485 and Modbus/TCP.

TB-64, TB-64D BACnet/IP.

TT-64, TT-64D Trend via ethernet. (Also requires an IQ3/4 outstation with spare memory).

The BACnet and Trend models also have Modbus available

The Black Pear can also be used on systems where a central controller is already present.

3.1 Product Variants

With Display

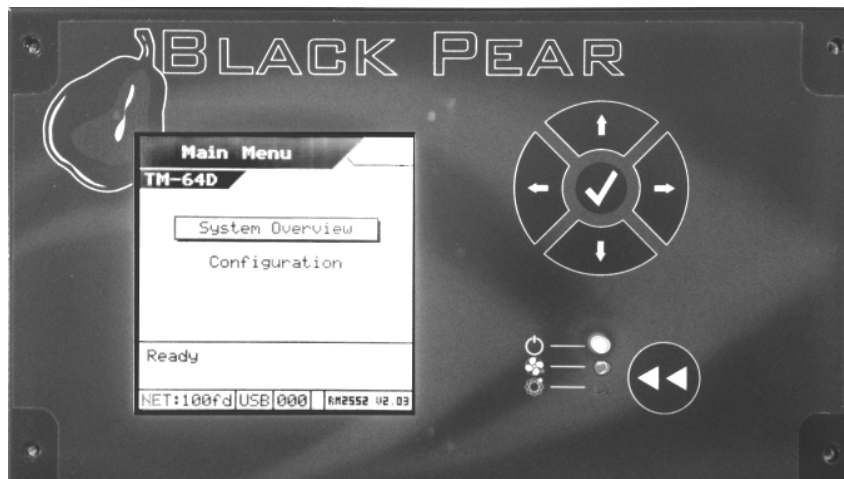

Without Display

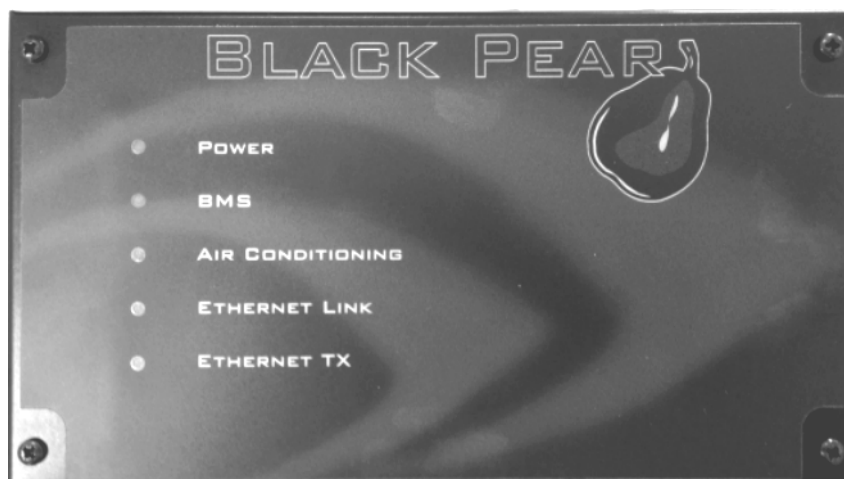

4. Connection Details

All electrical work should be carried out by a competent person and wiring must be in accordance with the national electrical installation regulations.

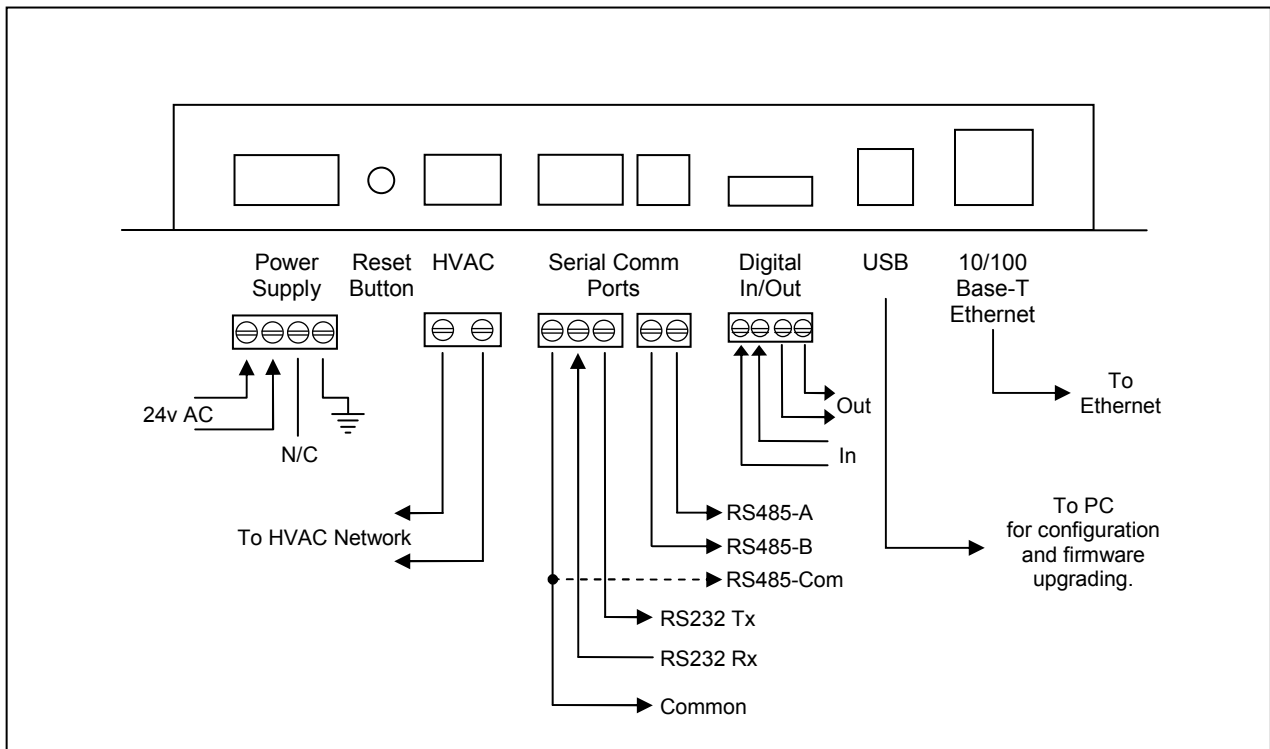

Fig. 1 Connection Details

4.1 Power Supply

The Black Pear requires a 24v AC supply and has a consumption not exceeding 5VA. The internal fuse is rated T630mA.

THIS EQUIPMENT MUST BE EARTHED

4.2 HVAC Communications Network (TCC-LINK)

Connect to outdoor unit terminals U3 and U4, as per a standard central controller. These are non-polarized.

4.3 Serial Communications Ports

These connectors provide access to the Modbus registers using RS232 or 2-wire RS485. The port configuration is as follows:

Modbus RTU
9600 baud, 8 data bits, no parity, 1 stop bit

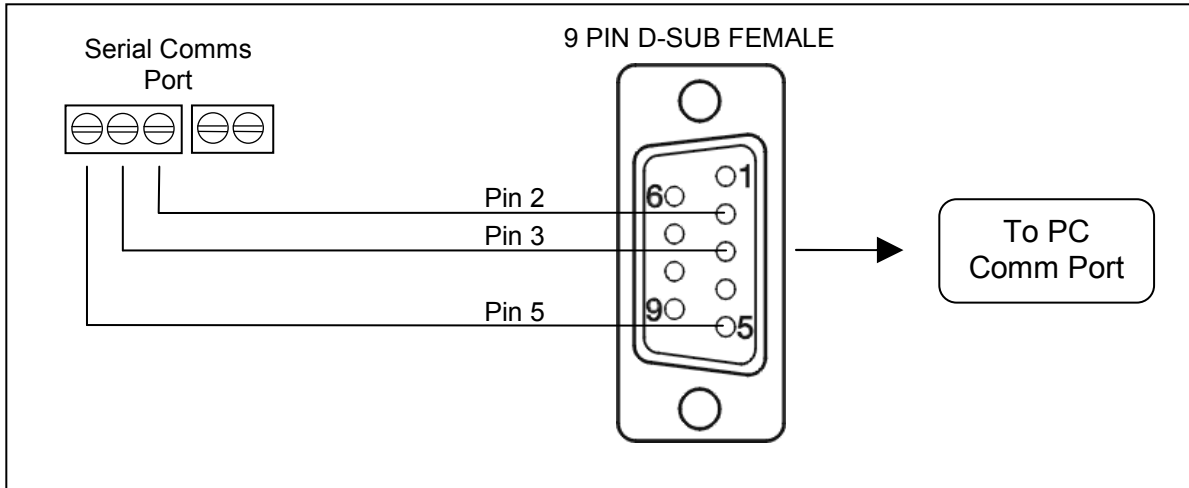

Fig. 2 RS232 Comms Lead Wiring Diagram

The RS485 interface can be used on a compatible serial communications network shared by multiple RS485 devices. The 'Base Slave Address' must be set to prevent multiple units using the same slave numbers.

It is recommended that screened twisted-pair cable is used. RS485-A is the non-inverting signal and is also named RS485+ RS485-B is the inverting signal and is also named RS485- Common should be connected to the cable screen.

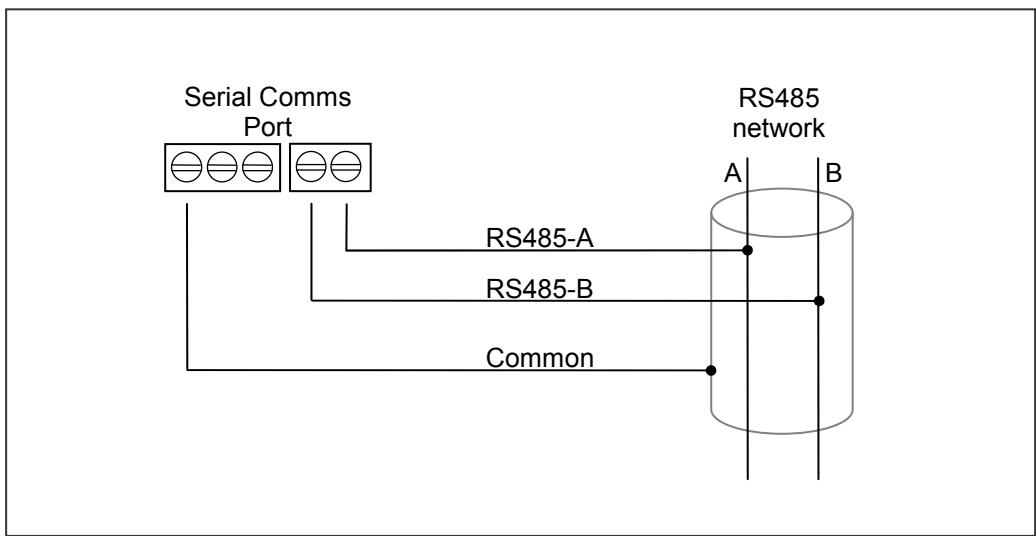

Fig. 3 RS485 Comms Lead Wiring Diagram

4.4 Digital Input / Output

As of firmware v2.27, the digital input functions as the 'Global Forced Off' signal. This is a normally-closed, volt-free signal.

Upon detecting an 'Open' input, all available fancoils will be switched off and their remote-controllers will be inhibited. These settings are refreshed every 10 seconds while the input is 'Open'.

When the input is subsequently 'Closed', the remote-controller inhibits are removed, but the fancoils remain off.

The digital output currently has no functionality.

4.5 USB

The USB interface is used for configuration via a PC and for upgrading the firmware.

Ensure that the correct USB driver has been installed prior to connecting the Black Pear to a PC.

4.6 Ethernet

The Black Pear is a 10/100Base-T half/full duplex device. It supports auto-negotiation and also features auto-crossover (Auto-MDIX), allowing the use of either a straight-through or crossover cable.

It does not currently support DHCP and will therefore require the IP address, gateway address and subnet-mask configuring to match the host network it is attached to.

If the unit is only being accessed via the local network then set the gateway address to be the same as the IP address, otherwise enter the address of the appropriate gateway or router.

5. Air-Conditioning Address Configuration

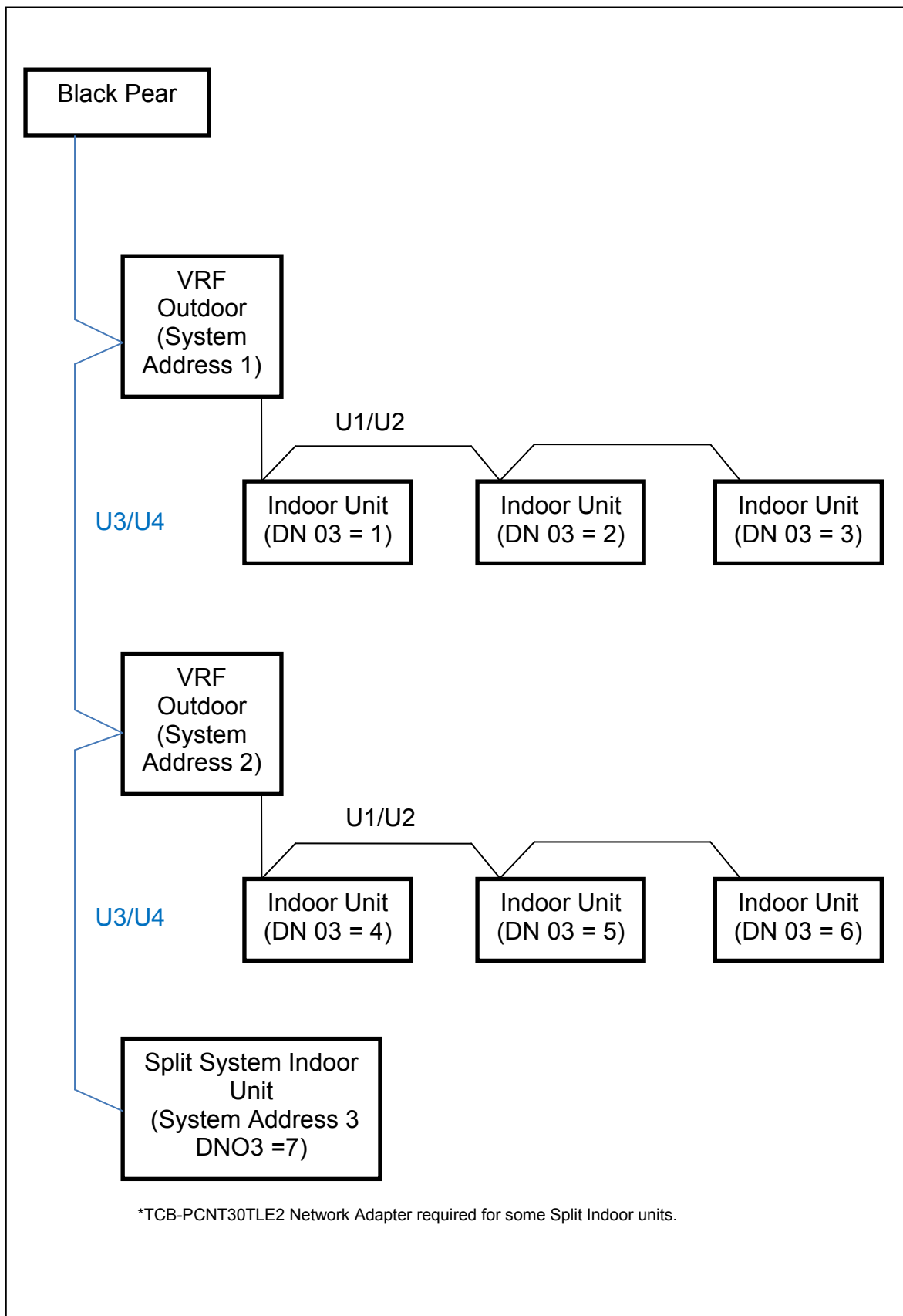

Fig. 4 Addressing Example

The systems need to be set up as if a standard Toshiba central controller is to be fitted. The Black Pear can replace or work in parallel with a Toshiba central controller.

Each refrigerant system must have a separate line address and the network address (Configuration Item 03) must be set between 1 and 64. If units are grouped via AB, the units will have the same network address and the status data for the follower units will not be available.

Units can be grouped within the Black Pear using the PC configuration software. The groupings determine which unit addresses can accept commands from the BMS system.

The group number is defined as 'the lowest indoor unit address within the group'. This then becomes the 'master' address for the group, and is the only address within that group that can accept commands.

The other units within a group can be classed as 'slave' units and contain the same status parameter values as the 'master', apart from Return Air Temp and Error Code, which are unique to each unit.

Attempting to write a command to a 'slave' unit will have no effect.

If you wish to be able to monitor slave units within a group, ensure that they are configured as individual units (via the A/C system) and grouped using the Black Pear.

6. User Interface (Display Version)

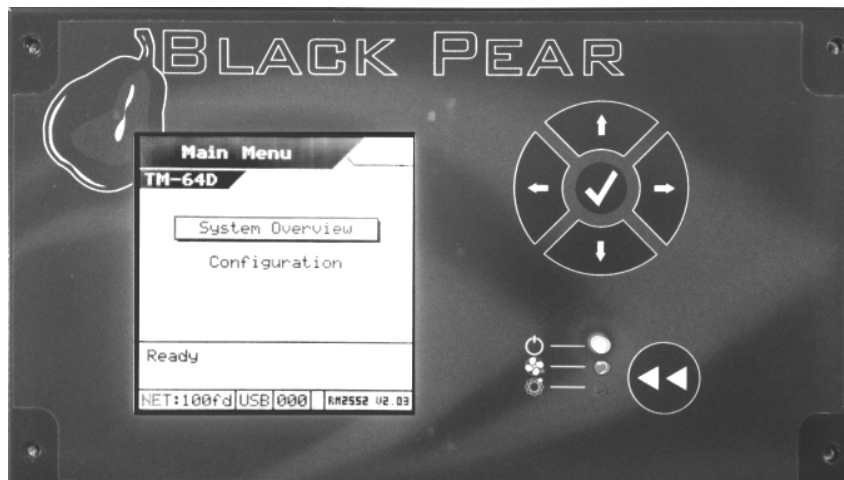

	Navigation Buttons
	Enter/Accept Button
	Back/Cancel Button

	Power LED
	HVAC Network LED Flashes on a valid incoming message
	BMS Network LED Flashes on a valid incoming message

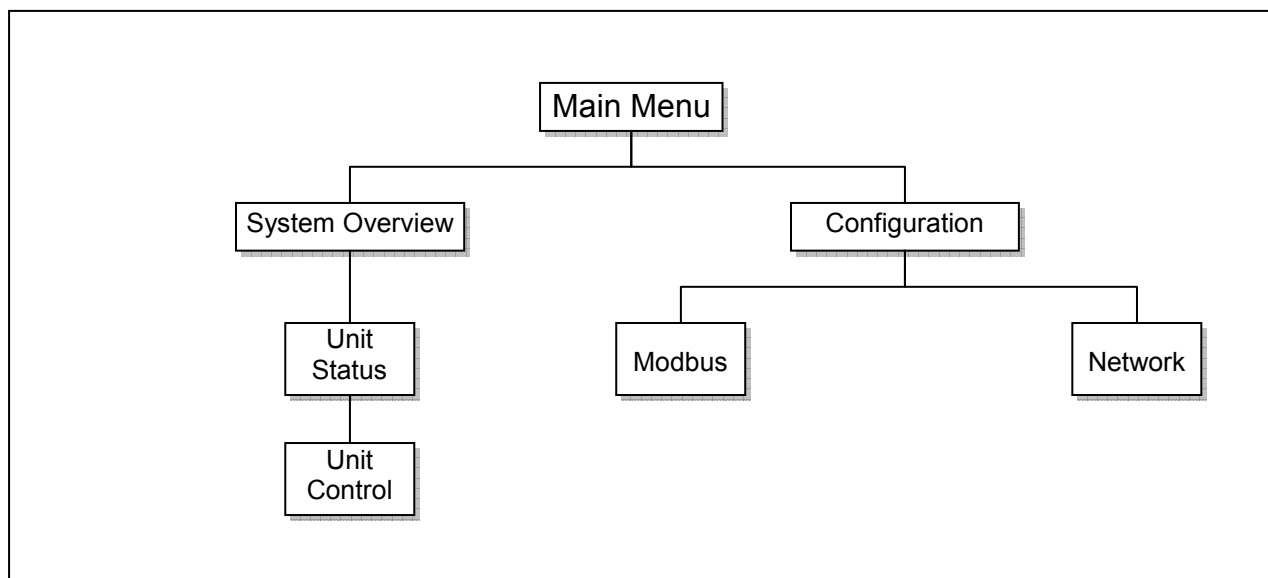
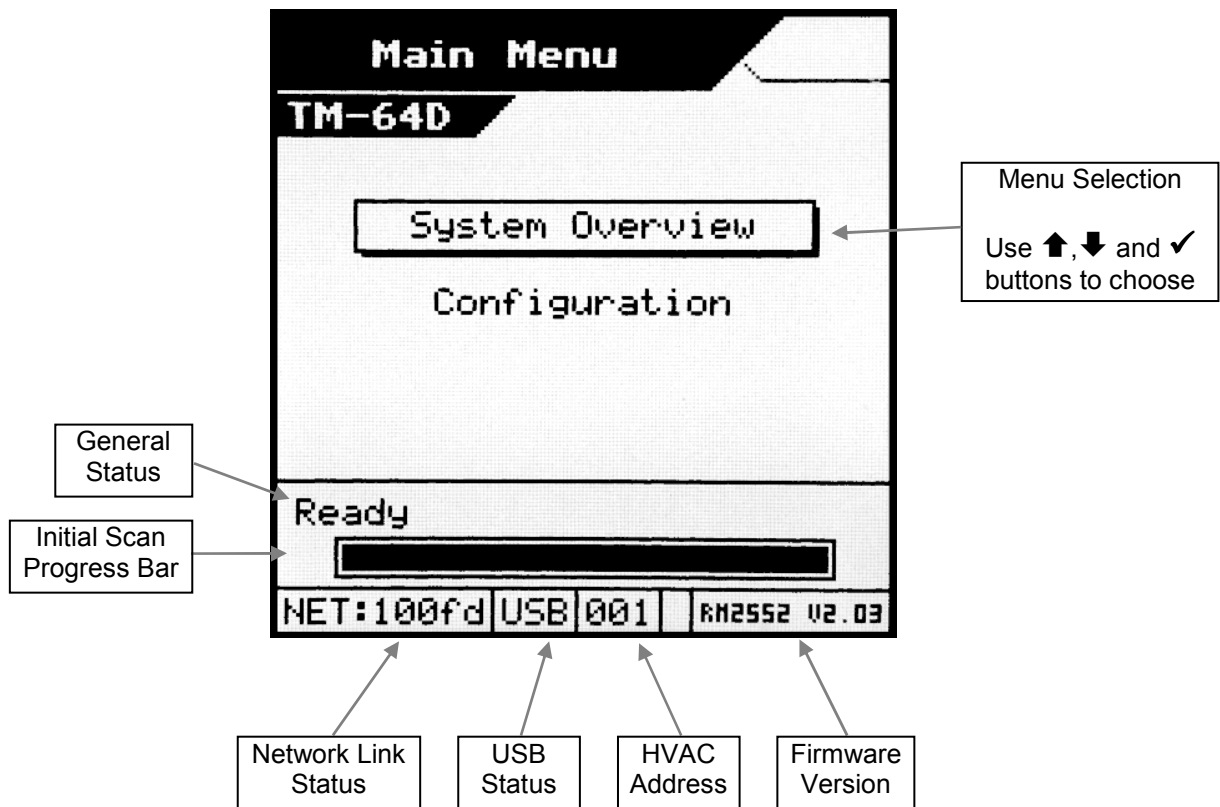

Fig. 5 Screen Hierarchy

6.1 Main Menu



General Status	Waiting...	The Black Pear has been restarted and is preparing to start scanning the HVAC network.
	Searching...	The Black Pear is performing an initial scan to determine which unit addresses are active on the HVAC network. The progress bar shows how much of the scan has been performed.
	Ready	The initial scan is complete.
Network Link Status	N/C	Not connected.
	???	Auto-negotiation in progress.
	10hd	10Mb half duplex
	10fd	10Mb full duplex
	100hd	100Mb half duplex
USB Status	100fd	100Mb full duplex
	<blank>	Not connected
	USB	Connected
HVAC Address	0	Fixed address when the Black Pear is acting as the central controller.
	1 to 127	User configured address when a central controller is already present on the system.

6.2 System Overview

Displays an 8 by 8 grid showing the address of any unit discovered by the Black Pear, in the address range 1 to 64.

Pressing the ◀◀ key will return to the Main Menu screen.

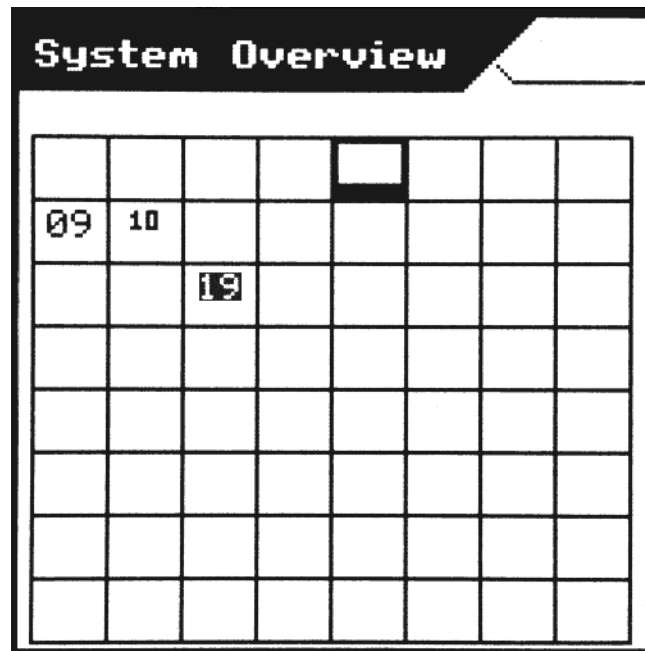

	Selection Cursor. Controlled using the navigation buttons. Pressing ✓ on a numbered cell will display the unit status screen.
	A large number is a 'Group Master'.
	A small number is a 'Slave Unit'.
	An inverted number indicates the unit is ON.
	A flashing number indicates the unit is in error.

6.3 Unit Status Screen

◀ 09 Unit009 Group 09 Master ▶	
Return Air	+25°C
Error Code	8000 [OK]
Operation	Off
Setpoint	24°C
Mode	Cool
Fan Speed	Medium
Air Direction	22.5°

**Group Master
Status Screen**

◀ 10 Unit010 Group 09 Slave ▶	
Return Air	+19°C
Error Code	8000 [OK]
Operation	Off
Setpoint	24°C
Mode	Cool
Fan Speed	Medium
Air Direction	22.5°

**Slave Unit Status
Screen**

This screen shows the status of a single fan coil.

Pressing the ◀ or ▶ key cycles backward and forward through all available fan coils. The ◀◀ key will return to the System Overview screen.

Only a 'Group Master' will show a cursor to allow the current settings to be altered.

Use the ↑, ↓ and ✓ keys to select a setting to be changed.

The appropriate parameter setting window will be displayed.

Use the ↑, ↓ keys to choose a new setting, ✓ to accept the change or ◀◀ to cancel the change.

7. Modbus Interface

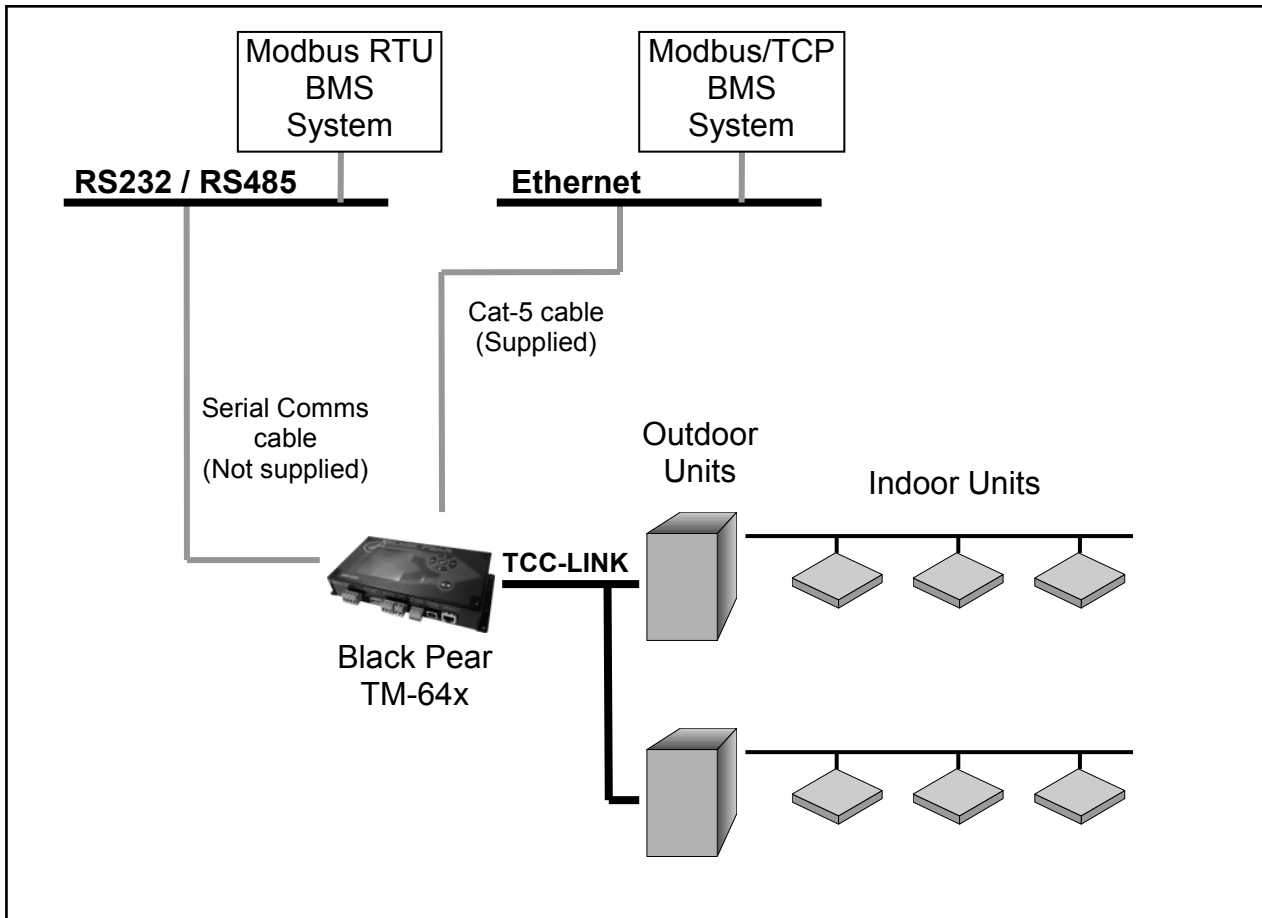

Fig. 6 Modbus System Example

7.1 Port Configurations

RS232/RS485 interface

Modbus RTU

9600 baud, 8 data bits, no parity, 1 stop bit

Network interface

Modbus/TCP

2 simultaneous Modbus/TCP client connections are supported:

1 only uses TCP port 502 (default Modbus/TCP port)

2 uses a user configurable TCP port number

Modbus functions supported

Fn 1 Read Coils

Fn 3 Read Holding Registers

Fn 5 Write Single Coil

Fn 6 Write Single Register

Fn 16 Write Multiple Registers (Max. 16 registers at once)

7.2 HVAC Status and Control Registers

The Black Pear TM-64x behaves as 24 modbus slaves. Slaves 1 to 22 each have 90 registers (Offset = 0 to 89). Slaves 23 and 24 are used for configuration.

The default 'Base Slave Address' is 1, meaning the Black Pear will respond to msgs for slaves 1 to 24. The Base Slave Address can be adjusted from 1 up to 200. A setting of 200 means the Black Pear will respond to msgs for slaves 200 to 223.

This is useful to prevent address clashing when the Black Pear unit is attached to a serial communications network containing multiple Modbus devices.

Some BMS systems have limited slave address resources, so the 'Single Slave Access' feature means the Black Pear can be configured to respond to just 1 slave address (i.e. the 'Base Slave Address' setting).

The Black Pear maps the data from the air conditioner units into Modbus registers accessed by two Modbus parameters 'Slave No.' and 'Offset'.

All slave numbers referred to in this document assume the default Base Address.

Slaves 1 to 21 each represent 3 units, and slave 22 represents 1 unit.

Each slave is organised as follows:

General Information			Extended Information			Extra Information		
Unit A	Unit B	Unit C	Unit A	Unit B	Unit C	Unit A	Unit B	Unit C
Offset 0	Offset 10	Offset 20	Offset 30	Offset 40	Offset 50	Offset 60	Offset 70	Offset 80

General information for a single unit		Extended information for a single unit		Extra information for a single unit	
Register Offset	Stored Value	Register Offset	Stored Value	Register Offset	Stored Value
0	Return Air Temp	0	Air Direction (R)	0	'Hi-res' Return Air
1	Error Code	1	Air Direction (W)	1	'Hi-res' Setpoint (R)
2	Setpoint (R)	2	Inhibit (R)	2	'Hi-res' Setpoint (W)
3	Mode (R)	3	Inhibit (W)	3	Unused
4	Fan Speed (R)	4	Ventilation (R) *	4	Unused
5	Setpoint (W)	5	Ventilation (W) *	5	Unused
6	Mode (W)	6	Error Code (DispA)	6	Unused
7	Fan Speed (W)	7	Error Code (DispB)	7	Unused
8	On/Off (R)	8	Reserved	8	Unused
9	On/Off (W)	9	Unused	9	Unused

See Section 7.5 for an overview of Modbus slave and offset usage..

Examples:

1) To read the current fan speed of unit 8

Single Slave Access = Off		
Slave	Function	Offset
3	3	14

Single Slave Access = On		
Slave	Function	Offset
1	3	194

2) To read the current mode of unit 48

Single Slave Access = Off		
Slave	Function	Offset
16	3	23

Single Slave Access = On		
Slave	Function	Offset
1	3	1373

* Not currently supported

On/Off and Inhibit can also be accessed via 'Coils'. Each slave contains 12 coils, organised as follows:

Coil Offset	Definition
0	Unit A On/Off (R)
1	Unit A On/Off (W)
2	Unit B On/Off (R)
3	Unit B On/Off (W)
4	Unit C On/Off (R)
5	Unit C On/Off (W)
6	Unit A Inhibit (R)
7	Unit A Inhibit (W)
8	Unit B Inhibit (R)
9	Unit B Inhibit (W)
10	Unit C Inhibit (R)
11	Unit C Inhibit (W)

Note

Coil access is not available when 'Single Slave Access' is enabled.

7.3 Additional Register Usage

Slave	Offset	Single Slave Offset	Description	Valid Settings
22	150	2040	HVAC Network Status	00: Waiting 01: Searching 02: Ready 03: Unknown
22	151	2041	System Force Off *	00: Not active 01: Active

See Section 9.5 for a description of the various settings.

* Not currently supported

7.4 Parameter Settings

Parameter	Settings	Notes
Return Air Temperature	-35°C to 92°C	Read-only
'Hi-res' Return Air	-35.0°C to 92.0°C	register contains the value multiplied by 10. eg. 235 = 23.5°C
Error Code	4 digit error code where 8000 = 'No Error' 6999 = 'Unit Not Present'	Read-only See Appendix D
Setpoint Temperature	18°C to 29°C	
'Hi-res' Setpoint	18.0°C to 29.0°C	register contains the value multiplied by 10. eg. 255 = 25.5°C
Operation Mode	00: Fan (Draft) 01: Cool 02: Heat 03: Dry 04: Auto 05: (Not Used)	
	06: AutoCool 07: AutoHeat	Not settable
	08: Heat Exchange 09: VN-Auto 10: VN-Bypass	VN units only
Fan Speed	00: Low 01: Medium 02: High 03: Auto	
On/Off	00: Off 01: On	
Air Direction	00: Horizontal 01: 22½ deg 02: 45 deg 03: 67½ deg 04: Vertical 05: Swing 06: Hold	
Local Inhibit	00: Not inhibited 01: Inhibited	
Ventilation	00: Off 01: Low 02: High	*

* Not currently supported

7.5 Modbus Table Overview

Unit Address	Slave	General Info Base Offset	Extended Info Base Offset	Extra Info Base Offset	Single Slave Access		Coil Base Offsets	
					General Info Base Offset	Extended Info Base Offset	On/Off	Inhibit
1	1	0	30	60	0	30	0	6
2	1	10	40	70	10	40	2	8
3	1	20	50	80	20	50	4	10
4	2	0	30	60	90	120	0	6
5	2	10	40	70	100	130	2	8
6	2	20	50	80	110	140	4	10
7	3	0	30	60	180	210	0	6
8	3	10	40	70	190	220	2	8
9	3	20	50	80	200	230	4	10
10	4	0	30	60	270	300	0	6
11	4	10	40	70	280	310	2	8
12	4	20	50	80	290	320	4	10
13	5	0	30	60	360	390	0	6
14	5	10	40	70	370	400	2	8
15	5	20	50	80	380	410	4	10
16	6	0	30	60	450	480	0	6
17	6	10	40	70	460	490	2	8
18	6	20	50	80	470	500	4	10
19	7	0	30	60	540	570	0	6
20	7	10	40	70	550	580	2	8
21	7	20	50	80	560	590	4	10
22	8	0	30	60	630	660	0	6
23	8	10	40	70	640	670	2	8
24	8	20	50	80	650	680	4	10
25	9	0	30	60	720	750	0	6
26	9	10	40	70	730	760	2	8
27	9	20	50	80	740	770	4	10
28	10	0	30	60	810	840	0	6
29	10	10	40	70	820	850	2	8
30	10	20	50	80	830	860	4	10
31	11	0	30	60	900	930	0	6
32	11	10	40	70	910	940	2	8
33	11	20	50	80	920	950	4	10
34	12	0	30	60	990	1020	0	6
35	12	10	40	70	1000	1030	2	8
36	12	20	50	80	1010	1040	4	10
37	13	0	30	60	1080	1110	0	6
38	13	10	40	70	1090	1120	2	8
39	13	20	50	80	1100	1130	4	10
40	14	0	30	60	1170	1200	0	6
41	14	10	40	70	1180	1210	2	8
42	14	20	50	80	1190	1220	4	10
43	15	0	30	60	1260	1290	0	6
44	15	10	40	70	1270	1300	2	8
45	15	20	50	80	1280	1310	4	10
46	16	0	30	60	1350	1380	0	6
47	16	10	40	70	1360	1390	2	8
48	16	20	50	80	1370	1400	4	10
49	17	0	30	60	1440	1470	0	6
50	17	10	40	70	1450	1480	2	8
51	17	20	50	80	1460	1490	4	10
52	18	0	30	60	1530	1560	0	6

Unit Address	Slave	General Info Base Offset	Extended Info Base Offset	Extra Info Base Offset	Single Slave Access		Coil Base Offsets	
					General Info Base Offset	Extended Info Base Offset	On/Off	Inhibit
53	18	10	40	70	1540	1570	2	8
54	18	20	50	80	1550	1580	4	10
55	19	0	30	60	1620	1650	0	6
56	19	10	40	70	1630	1660	2	8
57	19	20	50	80	1640	1670	4	10
58	20	0	30	60	1710	1740	0	6
59	20	10	40	70	1720	1750	2	8
60	20	20	50	80	1730	1760	4	10
61	21	0	30	60	1800	1830	0	6
62	21	10	40	70	1810	1840	2	8
63	21	20	50	80	1820	1850	4	10
64	22	0	30	60	1890	1920	0	6

8. Trend Interface (TT-64x only)

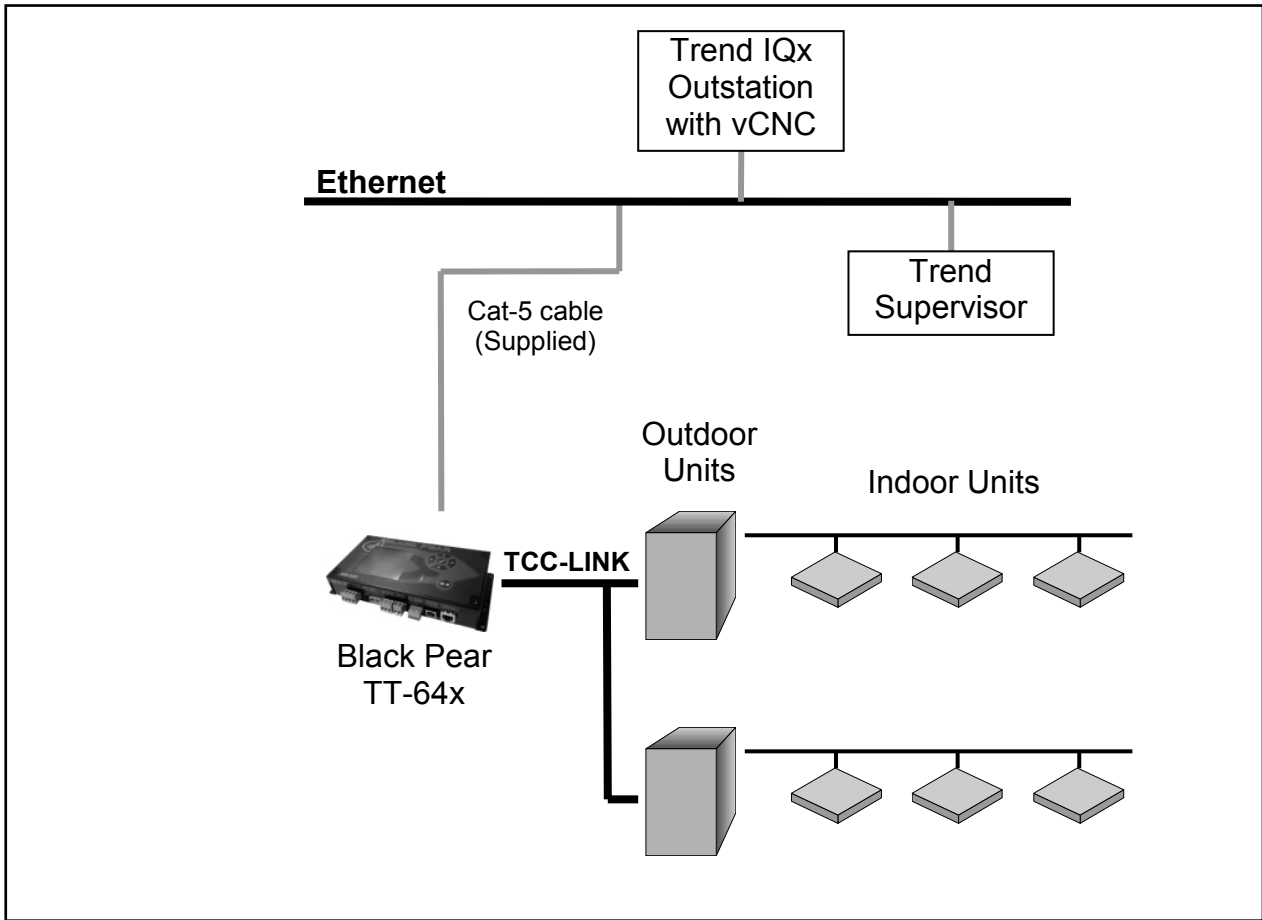

Fig. 7 Trend System Example

The Black Pear connects via Ethernet to a CNC or the virtual CNC port of a Trend IQ outstation, and uses sensors, switches and knobs defined in the IQx memory to mirror a range of HVAC parameters, making them available on a Trend network.

8.1 Trend Process Description

Startup Sequence

- 1) Power up
- 2) Waiting for initial scan
- 3) Perform initial HVAC scan
- 4) Initial scan complete
- 5) Connect to CNC port
- 6) Transfer current HVAC status to required Trend outstation (“First Pass”)
- 7) Disconnect from CNC port
- 8) Wait for re-connection time
- 9) Connect to CNC port
- 10) Poll the objects for each active HVAC unit in the Trend outstation, then either
Update the HVAC if the value of a Trend object has been altered, or
Update the Trend object if the value of an HVAC parameter has changed.
- 11) Disconnect from CNC port
- 12) Wait for re-connection time
- 13) Goto 9

At power-up, the Black Pear will wait for the initial HVAC scan to begin. During this scan, all available ‘active’ HVAC units are discovered. Once the scan is complete, the Black Pear will transfer all current parameter settings to the appropriate objects in the destination Trend outstation. This process is called the ‘First Pass’. This ensures that the values in the Black Pear and the Trend device are in sync. Until the ‘First Pass’ is complete, all commands sent from the Trend network to the Black Pear will be ignored.

The re-connection time is calculated from the CNC Usage setting within the Black Pear. This ensures that all Black Pear devices sharing a single CNC have enough time to connect.

Notes:

- ① Some Trend systems will generate ‘network alarms’ due to the repeated connection and disconnection of the Black Pear to the CNC.
Setting the CNC Usage = 0 will allow a single Black Pear to remain connected to the CNC, thus preventing these alarms from being generated.
This feature was added in firmware v2.19.

Following a reconfiguration of the Trend outstation, it is important that the Black Pear is restarted, to guarantee that all parameters are in sync.

8.2 Trend IQx Outstation Configuration

3 sensors (1 currently unused), 2 switches and 4 knobs are required to store all the parameters for a single unit.

The table below shows how to calculate the number of each object required :

Fan Coil Parameter	Sensor No.	Switch No.	Knob No.
Return Air	$S+((FC-1)*3)$		
Error Code	$S+((FC-1)*3)+1$		
'Unused'	$S+((FC-1)*3)+2$		
On/Off		$W+((FC-1)*2)$	
Inhibit		$W+((FC-1)*2)+1$	
Setpoint			$K+((FC-1)*4)$
Mode			$K+((FC-1)*4)+1$
Fan Speed			$K+((FC-1)*4)+2$
Air Direction			$K+((FC-1)*4)+3$

where

FC	= Fan Coil Address (1 to 64)	} Set using configuration software
S	= Sensor Base Address	
W	= Switch Base Address	
K	= Knob Base Address	

E.g.

If Sensor Base Address =100
 Switch Base Address = 50
 Knob Base Address = 50

then the following table shows the object numbers required for addresses 1,2,63 and 64.

	FC 1	FC 2	FC 63	FC 64
Sensors	100 to 101	103 to 104	286 to 287	289 to 290
Switches	50 to 51	52 to 53	174 to 175	176 to 177
Knobs	50 to 53	54 to 57	298 to 301	302 to 305

The Black Pear can be configured to enable only those objects of interest to the user, therefore reducing the memory overhead required in the IQ outstation. Any objects enabled in the Black Pear which aren't defined in the Trend outstation will simply be ignored during the polling sequence.

Note that this does not change the sensor, switch and knob numbers associated with each HVAC parameter.

If a sensor has been added to the sequence table then its 'Value' output must be connected to its 'Source Value' input, otherwise it will return a reading of zero.

See Appendix C for details of the memory requirements in the Trend outstation.

8.3 Parameter Settings

See the table in Section 7.4 for a list of valid parameter settings.

Notes:

① As of firmware v2.29, the return air sensor and the setpoint knob will contain temperatures valid to 1 dp (with 0.5°C resolution). Setting the setpoint to 1 dp is reliant on the HVAC unit accepting setpoint commands to this resolution.

9.BACnet Interface (TB-64x only)

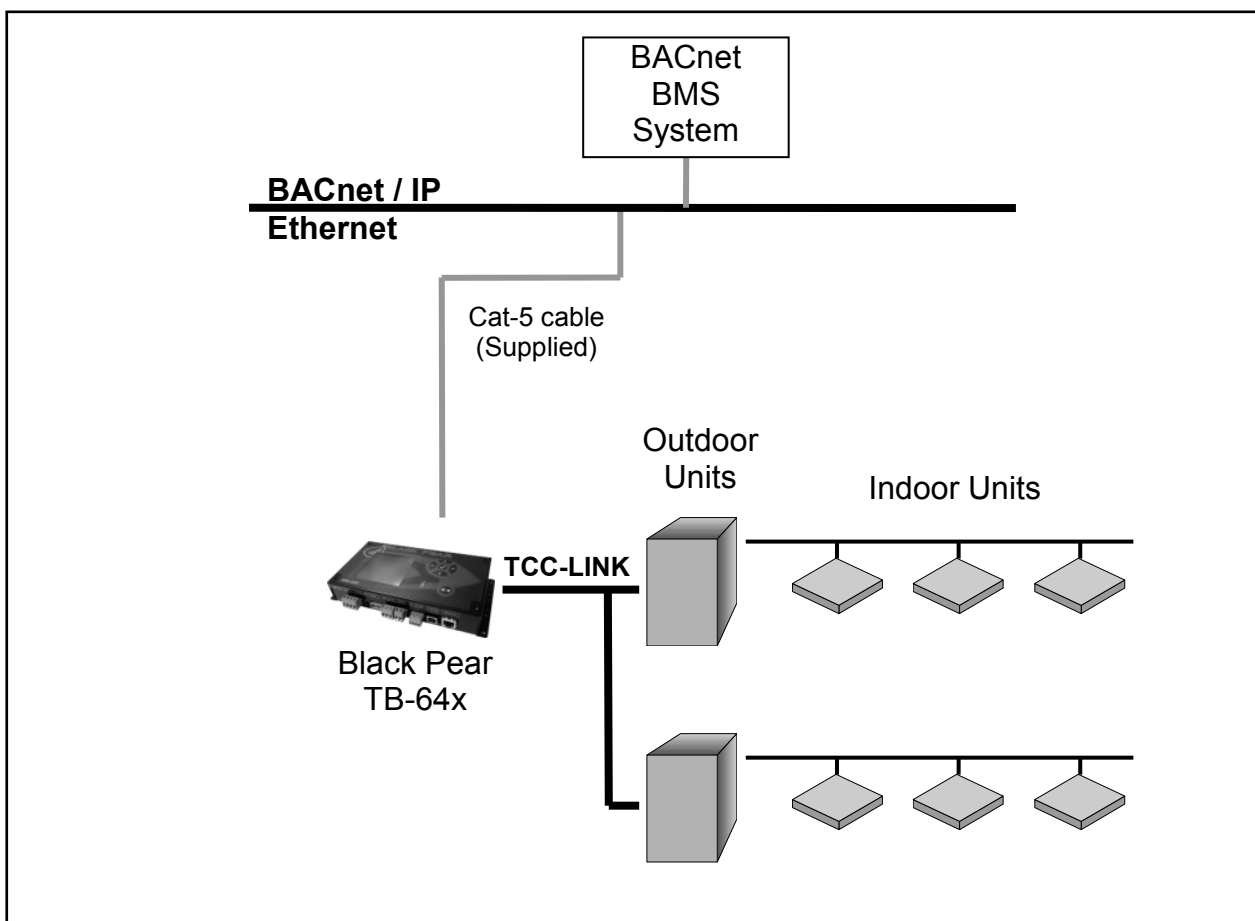

Fig. 8 BACnet System Example

The BLACK Pear TB-64x is designed to work with a BACnet/IP network as described in the ANSI/ASHRAE Standard 135-2004.

Property	Setting
Segmentation	Not Supported
Maximum APDU length supported	206 octets
Object List	Supported
Device ID	User settable ⁽¹⁾
Device Name	User settable ⁽¹⁾
Object Names	User settable ⁽¹⁾

Notes: (1) Only settable via PC configuration program.

9.1 Object Types

Object Type		Supported
Analog Input	0	Yes
Analog Output	1	Yes
Analog Value	2	
Binary Input	3	Yes
Binary Output	4	Yes
Binary Value	5	Yes
Calendar	6	
Command	7	
Device	8	Yes
Event Enrollment	9	
File	10	
Group	11	
Loop	12	
Multi-State Input	13	Yes
Multi-State Output	14	Yes
Notification Class	15	
Program	16	
Schedule	17	
Averaging	18	
Multi-State Value	19	
Trend Log	20	

9.2 Service List

Supported Services	
Read Property	12
Read Property Multiple	14
Write Property	15
Write Property Multiple	16
Who-Has	33
I-Have	27
Who-Is	34
I-Am	36

9.3 Object List

Object	Object Type	Instance No.	'Present Value' Settings	Notes
On/Off (Setup)	Binary Output	1xxx01	Inactive:Off Active:On	
On/Off (State)	Binary Input	1xxx02	Inactive:Off Active:On	
Error Code	Analog Input	1xxx03	4 digit error code where 8000= 'No Error' 6999= 'Unit Not Present'	See Appendix D
Operation Mode (Setup)	Multi-State Output	1xxx04	01: Fan 02: Cool 03: Heat 04: Dry 05: Auto 06: N/A	
			07: Auto Cool 08: Auto Heat	Not settable
			09: Heat Exchange 10: VN-Auto 11: VN-Bypass	VN units only
Operation Mode (State)	Multi-State Input	1xxx05	01: Fan 02: Cool 03: Heat 04: Dry 05: Auto 06: N/A	
			07: Auto Cool 08: Auto Heat	
			09: Heat Exchange 10: VN-Auto 11: VN-Bypass	VN units only
Fan Speed (Setup)	Multi-State Output	1xxx06	01: Low 02: Medium 03: High 04: Auto	
Fan Speed (State)	Multi-State Input	1xxx07	01: Low 02: Medium 03: High 04: Auto	
Room Temperature	Analog Input	1xxx08		①
Setpoint Temperature (Setup)	Analog Output	1xxx09	18.0°C to 29.0°C	①
Setpoint Temperature (State)	Analog Input	1xxx10	18.0°C to 29.0°C	①
Local Inhibit (Setup)	Binary Output	1xxx11	Inactive:Off Active:Inhibit	
Local Inhibit (State)	Binary Input	1xxx12	Inactive:Off Active:Inhibited	

Object	Object Type	Instance No.	'Present Value' Settings	Notes
Air Direction (Setup)	Multi-State Output	1xxx13	01: Horizontal 02: 22½ deg 03: 45 deg 04: 67½ deg 05: Vertical 06: Swing 07: Hold	
Air Direction (State)	Multi-State Input	1xxx14	01: Horizontal 02: 22½ deg 03: 45 deg 04: 67½ deg 05: Vertical 06: Swing 07: Hold	
Ventilation (Setup)	Multi-State Output	1xxx15	01: Off 02: Low 03: High	*
Ventilation (State)	Multi-State Input	1xxx16	01: Off 02: Low 03: High	*
(Unused)		1xxx17		
(Unused)		1xxx18		
(Unused)		1xxx19		
(Unused)		1xxx20		
(Unused)		1xxx21		
(Unused)		1xxx22		
HVAC Network Status	Multi-State Input	100023	01: Waiting 02: Searching 03: Ready 04: Unknown	
System Force Off	Binary Value	100024	Inactive:Off Active:On	*
Device	Device	zzz		zzz = 1 to 4194302

where xxx represents unit address 001 to 064

* Not currently supported

9.4 Object Names

Object	Object Name	Notes
On/Off (Setup)	nnn (ON_w)	
On/Off (State)	nnn (ON_r)	
Error Code	nnn (ECode)	
Operation Mode (Setup)	nnn (MD_w)	
Operation Mode (State)	nnn (MD_r)	
Fan Speed (Setup)	nnn (FS_w)	
Fan Speed (State)	nnn (FS_r)	
Room Temperature	nnn (RA)	①
Setpoint Temperature (Setup)	nnn (SP_w)	①
Setpoint Temperature (State)	nnn (SP_r)	①
Local Inhibit (Setup)	nnn (LI_w)	
Local Inhibit (State)	nnn (LI_r)	
Air Direction (Setup)	nnn (AD_w)	
Air Direction (State)	nnn (AD_r)	
Ventilation (Setup)	nnn (VN_w)	*
Ventilation (State)	nnn (VN_r)	*
HVAC Network Status	Sys_HVAC_Network_Status	
System Force Off	Sys_Force_Off	

where 'nnn' is the unit name entered via the configuration program.

① As of firmware v2.29, the room temperature object and the setpoint read and write objects will contain temperatures valid to 1 dp. Setting the setpoint to 1 dp is reliant on the HVAC unit accepting setpoint commands to this resolution.

* Not currently supported

9.5 System Objects

There are 2 'System' objects contained within the Black Pear, which are classed as global objects. A description of each is detailed below.

System Object	Description
HVAC Network Status	<p>Read-only object providing an indication of the communication status between the Black Pear and the HVAC network. The various states are defined as follows:</p> <p><u>Waiting:</u> The Black Pear has been restarted and is preparing to start scanning the HVAC network.</p> <p><u>Searching:</u> The Black Pear is performing its initial scan of the HVAC network, looking for active units with addresses in the range 1 to 64.</p> <p><u>Ready:</u> The initial scan is complete and the Black Pear will now accept new commands.</p> <p><u>Unknown:</u> An undefined state has been detected.</p> <p><u>Note:</u> Until the status = 'Ready', commands send to the Black Pear will be ignored.</p>
System Force Off	<p>Writeable object to enable and disable the global off command.</p> <p><u>Note:</u> This object appears in the object list but its function is currently disabled.</p>

Appendix A : Physical Dimensions

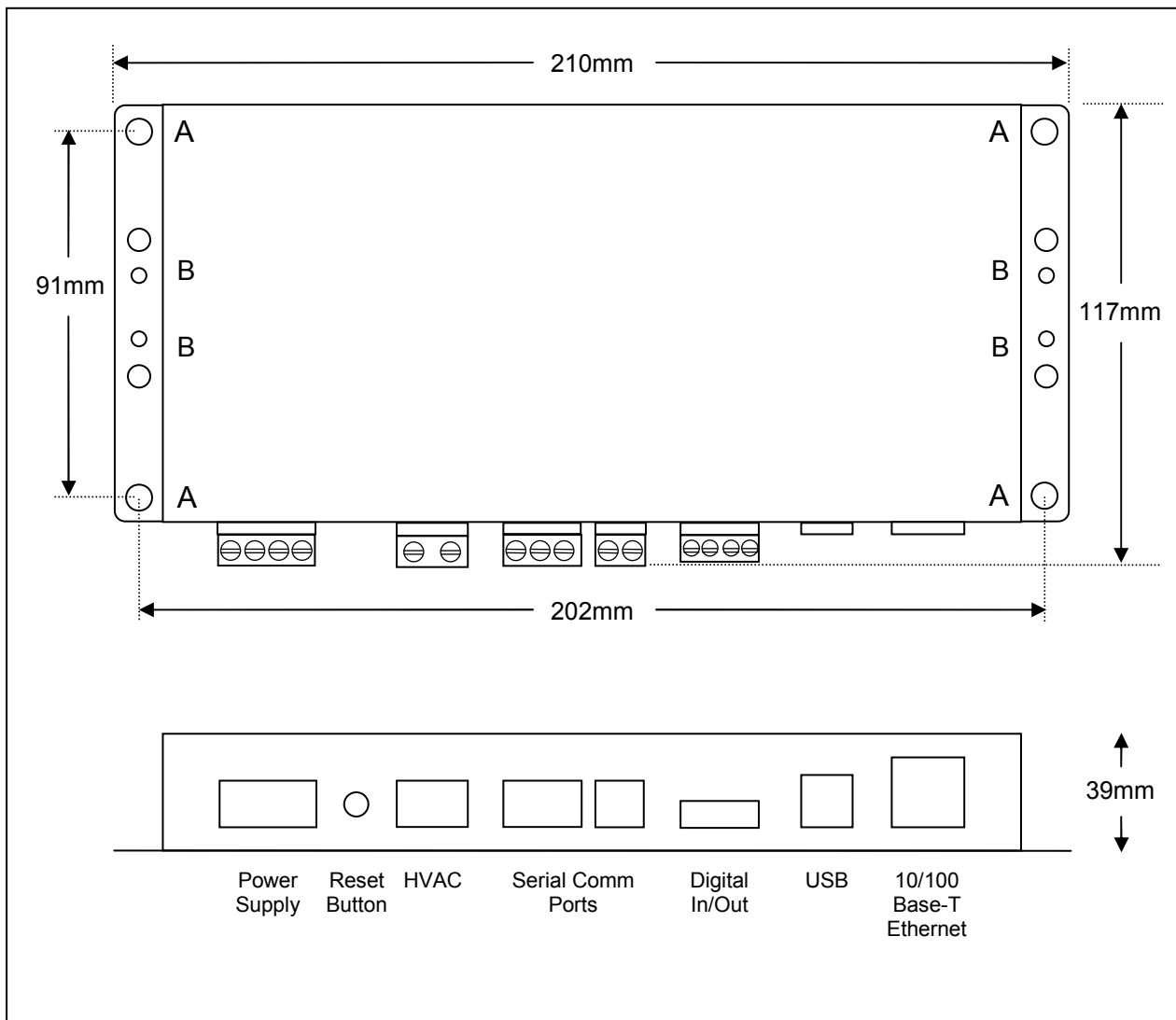

Fig. 9 Dimensions

The holes marked 'A' should be used when mounting the enclosure on a back panel.
The holes marked 'B' can be used to attach the supplied din-rail clips.

Appendix B : Reset Button and Factory Defaults

The Reset Button has 2 functions :

- 1) To restore various internal settings to their factory default,
- 2) To force the unit into 'bootloader' mode ready for a firmware update.

Function 1 – Restore Factory Defaults

There are 2 levels to this function.

Level 1: With the unit already ON, press and hold in the reset button.
After approximately 5 seconds, and depending on the type of unit, either the 'Power' led will start to flash slowly (approx 3 per second) or the 'Level-1 Reset' message will be displayed. Releasing the reset button at this point will activate Level 1, and then reset the unit.

Settings Restored: None

Level 2 : With the unit already ON, press and hold in the reset button.
After approximately 5 seconds, and depending on the type of unit, either the 'Power' led will start to flash slowly (approx 3 per second) or the 'Level-1 Reset' message will be displayed. Continue to hold in the reset button until either the 'Power' led starts to flash rapidly (approx 10 per second), or the 'Level-2 Reset' message is displayed. Releasing the reset button at this point will activate Level 2, and then reset the unit.

Settings Restored:

Device Name	'product specific name'
IP Address	192.168.1.20
Gateway Address	192.168.1.20
Subnet Mask	255.255.255.0
Base Slave Address	1
Single Slave Access	Off
Alternate Modbus/TCP Port	502
HVAC Address	1
Central Controller	Present
Group Configuration	Cleared

Additional Setting Restored for Trend Interfaces (TT-64x):

Pin Code	Disabled
Sensor Base Address	100
Switch Base Address	50
Knob Base Address	50
Object Enable Mask	All Objects Enabled
OutStation Address	2
CNC IP Address	192.168.1.1
CNC Address	1
CNC Port Number	10001
CNC Usage	1

Additional Settings Restored for BACnet Interfaces (TB-64x):

Device ID	200
UDP Port	47808
New Setting Comparison	Disabled
Register as Foreign Device	Disabled
Foreign Device Reg TTL	1800 seconds
Preserve PVs & PAs	Disabled
Input PV -> Output PV	Disabled

Function 2 – Enable 'Bootloader' Mode

Bootloader mode allows the firmware to be updated from a PC.

Press and hold in the reset button while powering up the unit. Continue to hold in the reset button for approx. 5 seconds. The unit is now in bootloader mode.

Note:

Enabling the bootloader in this way is only necessary if the firmware update software fails to automatically put the unit into bootloader mode.

Appendix C : Trend Outstation Memory Usage (TT-64x only)

1) The table below shows how much memory (in brIQs) each parameter requires :

Parameter	Trend Module	Size (brIQs)	Comments
Return Air Temp	Sensor	76	
Error Code	Sensor	76	
On/Off	Switch	10	
Inhibit	Switch	10	
Setpoint	Knob	13	
Mode	Knob	13	
Fan Speed	Knob	13	
Air Direction	Knob	13	

2) A Trend IQ3 has a capacity of 10000 to 45000 brIQs depending on the model and an IQ41x has a capacity of 10000 brIQs.

	IQ3xcite	IQ3xact	IQ3xcite			IQ41x
I/O Max	0	12	16	96	128	
IQ3 brIQs	-	10,000	30,000	30,000	37,000	-
IQ3/XNC brIQs	45,000	20,000	-	45,000	-	-
IQ41x brIQs						10,000

3) This table shows the number of brIQs needed for various system sizes and parameter requirements:

Parameter Usage	brIQs per FC	16 FC system	32 FC system	64 FC system
All parameters	224	3584	7168	14336
Return Air Error Code	152	2432	4864	9728
Return Air Error code On/Off Setpoint	175	2800	5600	11200
Return Air Error Code On/Off Inhibit Setpoint Mode Fan Speed	211	3376	6752	13504

4) This table shows the absolute maximum number of FCs which can be stored in various Trend outstations.

Parameter Usage	IQ3xcite/ XNC	IQ3xact	IQ3xact/ XNC	IQ3xcite/ 16	IQ3xcite/ 96	IQ3xcite/ 128	IQ41x
All parameters	200	44	89	133	133	165	44
Return Air Error Code	296	65	131	197	197	243	65
Return Air Error code On/Off Setpoint	257	57	114	171	171	211	57
Return Air Error Code On/Off Inhibit Setpoint Mode Fan Speed	213	47	94	142	142	175	47

Note:

- 1) When calculating the number of outstations required for a system, it is recommended to allow some spare capacity for strategy and other configuration data.
- 2) A single Black Pear device can only communicate with 1 Trend outstation, but multiple Black Pears can communicate with the same Trend outstation, provided there is enough memory in the Trend unit.

Appendix D : Toshiba Error Code Cross-Reference

Black Pear Error Code	Toshiba Error Code	Description
1005	C05	Sending error in TCC-LINK central control device
1006	C06	Receiving error in TCC-LINK central control device
1012	C12	Batch alarm of general-purpose equipment control interface
2001	E01	Communication error between indoor and remote controller (Detected at remote controller side)
2002	E02	Sending error of remote controller
2003	E03	Communication error between indoor and remote controller (Detected at indoor side)
2004	E04	Communication circuit error between indoor and outdoor (Detected at indoor side)
2006	E06	Decrease of No. of indoor units
2007	E07	Communication circuit error between indoor/outdoor (Detected at outdoor side)
2008	E08	Duplicated indoor addresses
2009	E09	Duplicated master remote controllers
2010	E10	Communication error between indoor P.C.board
2012	E12	Automatic address start error
2015	E15	No indoor automatic address
2016	E16	Capacity over / No. of connected indoor units
2018	E18	Communication error between indoor header and follower units
2019	E19	Outdoor header units quantity error
2020	E20	Other line connected during automatic address
2023	E23	Sending error in communication between outdoor units
2025	E25	Duplicated follower outdoor address
2026	E26	Decrease of No. of connected outdoor units
2028	E28	Follower outdoor unit error
2031	E31	IPDU communication error
3001	F01	Indoor TCJ sensor error
3002	F02	Indoor TC2 sensor error
3003	F03	Indoor TC1 sensor error
3004	F04	TD1 sensor error
3005	F05	TD2 sensor error
3006	F06	TE1 sensor error
3007	F07	TL sensor error
3008	F08	TO sensor error
3010	F10	TA sensor error
3012	F12	TS1 sensor error
3013	F13	TH sensor error
3015	F15	Outdoor temp. sensor misconnection (TE1,TL)
3016	F16	Outdoor pressure sensor misconnection (Pd,Ps)
3023	F23	Ps sensor error
3024	F24	Pd sensor error
3029	F29	Indoor other error
3031	F31	Outdoor EEPROM error
4001	H01	Compressor break down
4002	H02	Magnet switch error / Overcurrent relay operation / Compressor error (lock)
4003	H03	Current detection circuit error
4004	H04	Comp-1 case thermo operation
4006	H06	Low pressure protective operation
4007	H07	Low oil level protection
4008	H08	Oil level temp. sensor error
4014	H14	Comp-2 case thermo operation
4016	H16	Oil level detection circuit error / Magnet switch error / Overcurrent relay error

Black Pear Error Code	Toshiba Error Code	Description
6003	L03	Duplicated indoor header units
6004	L04	Duplicated outdoor line address
6005	L05	Duplicated indoor units with priority (Displayed in indoor unit with priority)
6006	L06	Duplicated indoor units with priority (Displayed in unit other than indoor unit with priority)
6007	L07	Group line in individual indoor unit
6008	L08	Indoor group/Address unset
6009	L09	Indoor capacity unset
6010	L10	Outdoor capacity unset
6020	L20	Duplicated central control addresses
6028	L28	Maximum number of outdoor units exceeded
6029	L29	No. of IPDU error
6030	L30	Auxiliary interlock in indoor unit
6031	L31	IC error
7001	P01	Indoor fan motor error
7003	P03	Discharge temp. TD1 error
7004	P04	High-pressure switch detection error
7005	P05	Phase-missing detection / Phase order error
7007	P07	Heat sink overheat error
7010	P10	Indoor overflow error
7012	P12	Indoor fan motor error
7013	P13	Outdoor liquid back detection error
7015	P15	Gas leak detection
7017	P17	Discharge temp. TD2 error
7019	P19	4-way valve inverse error,
7020	P20	High-pressure inverse error
7022	P22	Outdoor fan IPDU error
7026	P26	G-Tr short circuit protection error
7029	P29	Comp position detection circuit error
7030	P30	Follower indoor unit error (Group error)
7031	P31	Follower indoor unit error (Group error)

Note: For further information regarding the above error codes, please contact your local Toshiba A/C supplier, or Toshiba A/C technical support.

Special Black Pear Error Codes	Description
6999	Unit does not exist on the system
8000	No error detected

Appendix E : Document Revision History

Date	Document Ver	Firmware Ver	By	Comments
06/08/2013	v1.00	v2.03	mcb	Started Toshiba specific manual.
12/08/2013	v1.01	v2.04	mcb	First draft version.
02/10/2013	v1.02	v2.07	mcb	First complete version Added example addressing diagram. Added error code cross-reference.
01/05/2014	v1.03	v2.17	mcb	Corrected some typo errors
23/05/2014	v1.04	v2.18	mcb	Important Information now includes comment about configuration software. Added P30 error code.
17/12/2014	v1.05	v2.26	mcb	Corrected typo in section 7.2
23/04/2015	v1.06	v2.27	mcb	updated section 4.4 to describe 'Global Forced Off' feature.
11/11/2015	v1.07	v2.29	mcb	Modbus registers now include 'hi-res' RA and SP. Trend and BACnet sections now mention 'hi-res' RA and SP.
23/12/2015	v1.08	v2.30	mcb	Added VN heat exchanger modes. Corrected mode list in BACnet object table.

Microtrol Ltd
16 Elgar Business Centre
Moseley Road
Hallow
Worcester
WR2 6NJ
UK

Tel: +44 (0)1905 641910

Email: sales@microtrol.co.uk